

Annual maintenance

important notices

Removing the covers of the machine should only be done by a trained technician. When removing covers always make sure the machine is switched off and the power cord has been removed.

More info about the [removal of the covers can also be found here](#)

Periodic maintenance is of utmost importance to keep your machine in optimal working condition and to give it a long lifecycle.

When performing periodic maintenance, try to follow the prescriptions which follow hereunder.

It may be a good idea to write down your maintenance activities in a table.

- Once a year the dust, debris and chips which ended up under the side and rear covers have to be removed.
- First make sure you have sufficient free space to put all of the parts which have to be removed from the machine.
- Switch on the machine, home the spindle and then move the spindle approximately to the middle of the engraving table in the X-axis and all the way to the front.
- Remove engraving material and sticky mat from the engraving table and lower the spindle till it touches the table.
- Switch off the machine and remove the power cord.
- Then to remove the left and the right side covers, do the following:
- Switch off the machine and pull out the power cord from the rear of the machine.
- Remove the Ethernet cable from the rear side of the machine.
- Remove the screws, indicated on the image below (for the left cover).

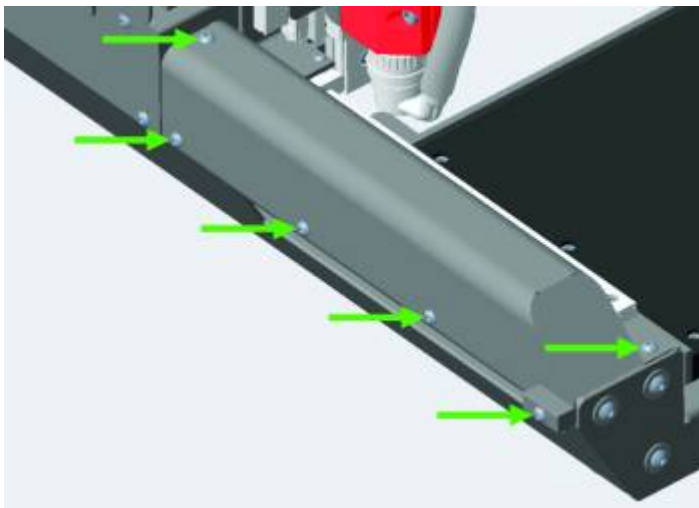

- Remove the screws, indicated on the image below (for the right cover)

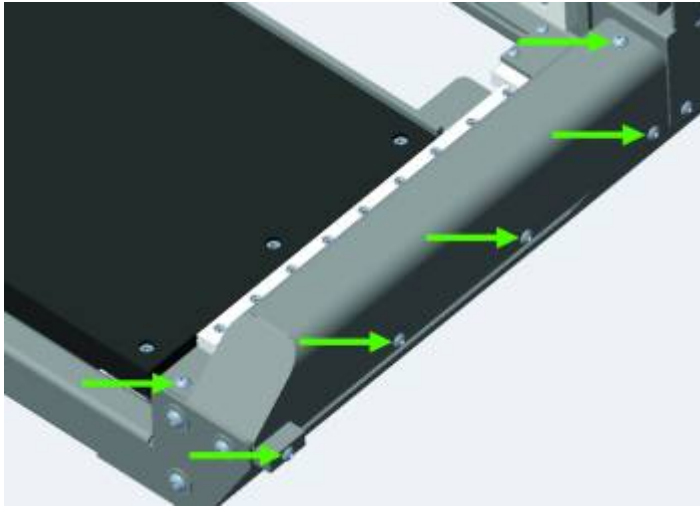

- Remove the 2 covers.
- Remove the 2 nuts which connect the gas springs to the machine cover.
- Remove the 2 screws which are part of the hinges of the protective cover of the machine. (see the images below)

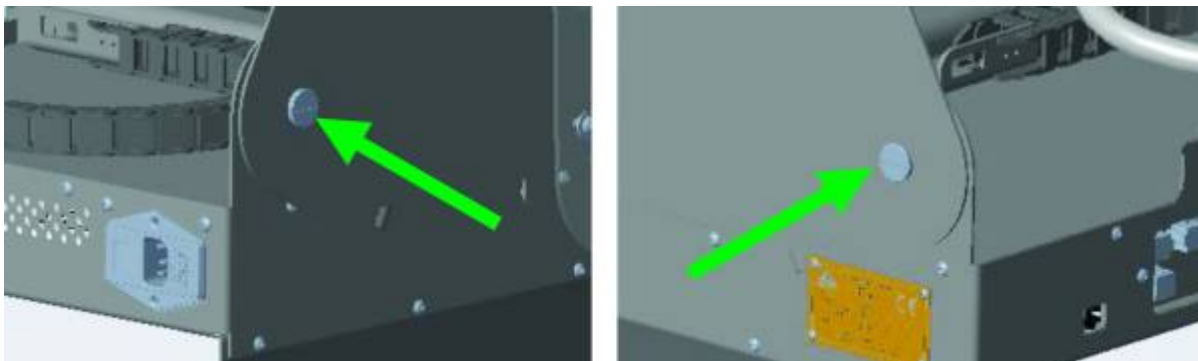

- Remove the screws, indicated on the images below (for the back cover).

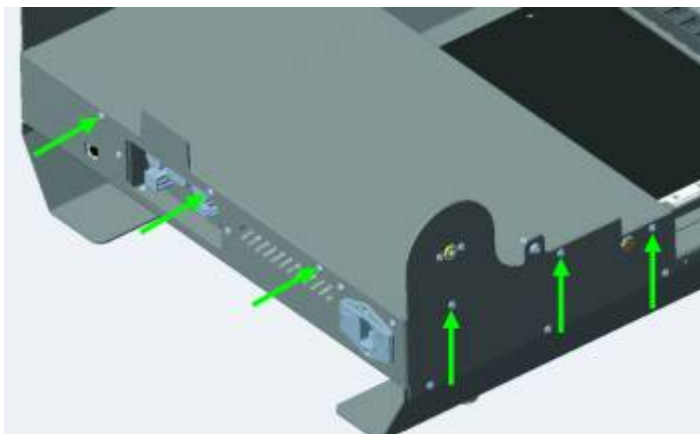

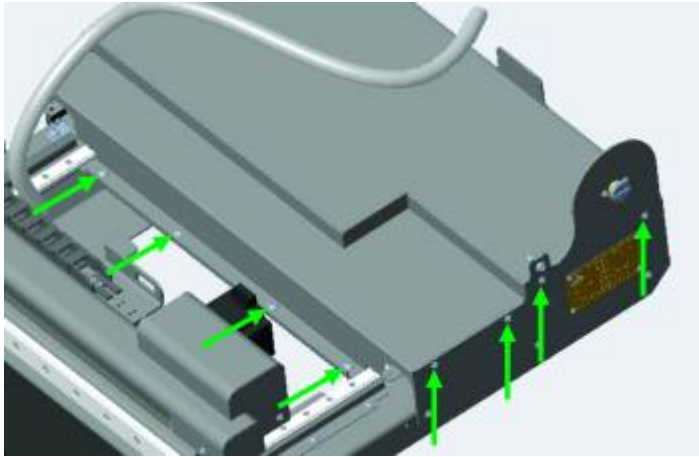

- Remove the top cover upwards and at the same time slightly to the rear.
- Using a vacuum cleaner, remove all the dust and debris which might have entered the electronics part of the machine. Make sure the machine has been switched off and the power cord has been removed.
- Check the insides of the three covers and remove the dust which might have been built up there. Pay attention especially at the double line of perforations on the right side of the rear cover and make sure any dust is removed from there.

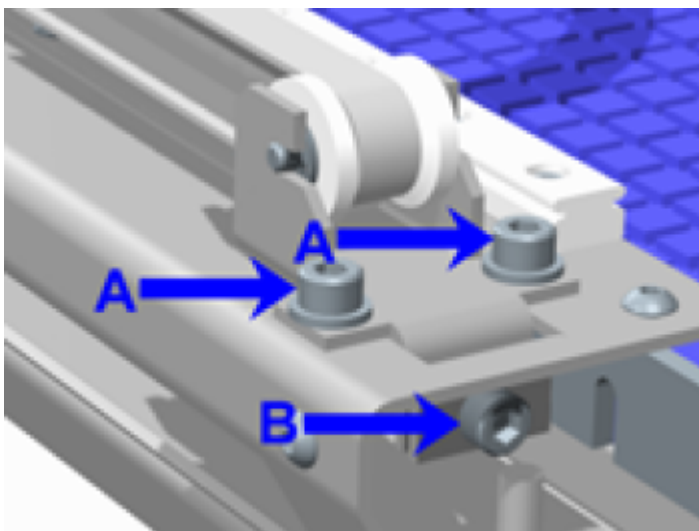

- With these covers removed, check if the Y-axis timing belts and the timing pulleys are in good shape.
- Manually push the gantry to the rear, or pull it to the front, so that you can inspect all of the teeth of the timing belts.
- If the timing belts are not really well tensioned anymore it is possible to retighten them.
- To do so you will first have to unscrew hex screws A (2 pieces). Do not take them out, unscrew them about one turn.
- After that you will need a torque wrench to apply the right tension to screw B. Release screw B a little bit, put the torque wrench in hex screw B, apply a tension of **1,2 Nm**, and tightly rescrew both the A screws.

Note: to have access to screw B you will first have to remove the front cover and the inner side covers. In the image hereabove you see the belt pulling mechanism of the left timing belt. The timing belt on the right hand side has an identical setup.

- The tension of the X-axis belt has to be checked also. Removing the X-axis belt cover can be done

as follows:

- Remove the cover of the X-axis stepper motor.
 - Remove the 4 screws which fix the X-axis cover. Two of them are in front of the cover, and there are two more in the back of the cover.
 - It is impossible to remove the cover without first loosening the spindle carriage. To do so, remove the 2 screws indicated with a yellow arrow (see image below)
 - The procedure to tighten the X-axis belt is identical to the procedure to tighten the Y-axis belts.
- Meer gedetailleerde info over het verwijderen van de afdekkap van de X-as vind je [hier](#)

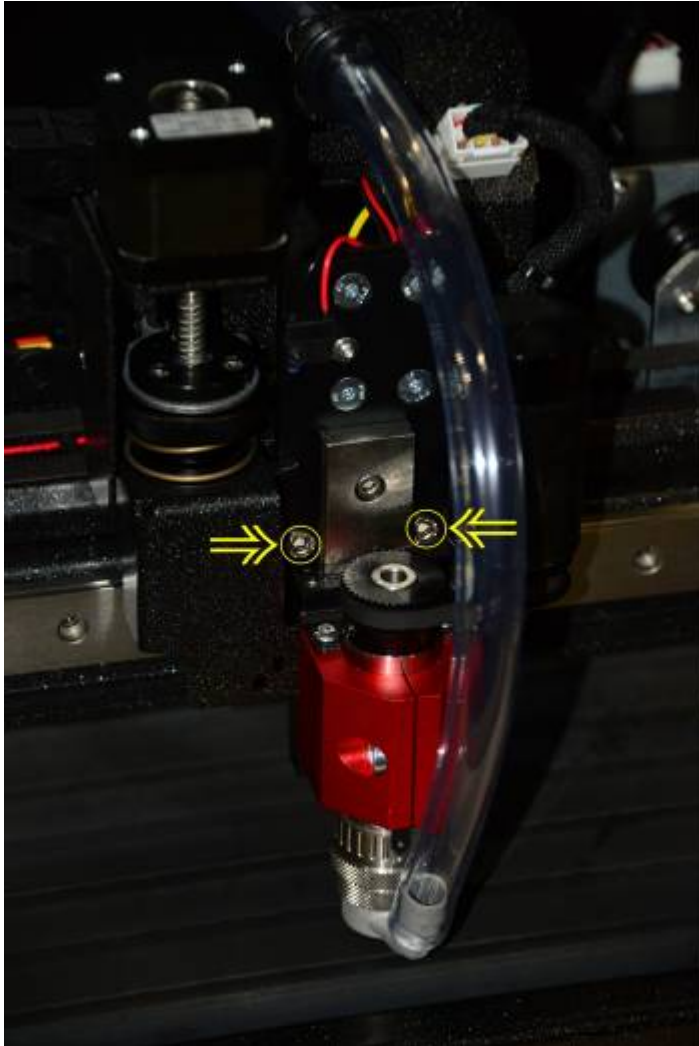

Continue to [replacing the spindle belt](#).
Continue to [the table of contents](#).

From:
<https://manuals.cyborg-engravers.com/> - **cyborg-engravers**

Permanent link:
<https://manuals.cyborg-engravers.com/doku.php?id=es:x300:annual>

Last update: **2022/12/05 21:10**

